



IR Alpha Inv **EXPERT**



INSTALLATION AND USER MANUAL
for your heat pump

Warning



This heat pump contains a flammable refrigerant R32.

Any intervention on the refrigerant circuit is prohibited without a valid authorization.

Before working on the refrigerant circuit, the following precautions are necessary for safe work.

1. Work procedure

The work must be carried out according to a controlled procedure, in order to minimize the risk of presence of flammable gases or vapors during the execution of the works.

2. General work area

All persons in the area must be informed of the nature of the work in progress. Avoid working in a confined area. The area around the work area should be divided, secured and special attention should be paid to nearby sources of flame or heat.

3. Verification of the presence of refrigerant

The area should be checked with a suitable refrigerant detector before and during work to ensure that there is no potentially flammable gas. Make sure that the leak detection equipment used is suitable for flammable refrigerants, ie it does not produce sparks, is properly sealed or has internal safety.

4. Presence of fire extinguisher

If hot work is to be performed on the refrigeration equipment or any associated part, appropriate fire extinguishing equipment must be available. Install a dry powder or CO2 fire extinguisher near the work area.

5. No source of flame, heat or spark

It is totally forbidden to use a source of heat, flame or spark in the direct vicinity of one or more parts or pipes containing or having contained a flammable refrigerant. All sources of ignition, including smoking, must be sufficiently far from the place of installation, repair, removal and disposal, during which time a flammable refrigerant may be released into the surrounding area. Before starting work, the environment of the equipment should be checked to ensure that there is no risk of flammability. «No smoking» signs must be posted.

6. Ventilated area

Make sure the area is in the open air or is properly ventilated before working on the system or performing hot work. Some ventilation must be maintained during the duration of the work.

7. Controls of refrigeration equipment

When electrical components are replaced, they must be suitable for the intended purpose and the appropriate specifications. Only the parts of the manufacturer can be used. If in doubt, consult the technical service of the manufacturer.

The following controls should be applied to installations using flammable refrigerants:

- *The size of the load is in accordance with the size of the room in which the rooms containing the refrigerant are installed;*
- *Ventilation and air vents work properly and are not obstructed;*
- *If an indirect refrigeration circuit is used, the secondary circuit must also be checked.*
- *The marking on the equipment remains visible and legible. Illegible marks and signs must be corrected;*
- *Refrigeration pipes or components are installed in a position where they are unlikely to be exposed to a substance that could corrode components containing refrigerant*

8. Verification of electrical appliances

Repair and maintenance of electrical components must include initial safety checks and component inspection procedures. If there is a defect that could compromise safety, no power supply should be connected to the circuit until the problem is resolved.

Initial security checks must include:

- *That the capacitors are discharged: this must be done in a safe way to avoid the possibility of sparks;*
- *No electrical components or wiring are exposed during loading, recovery or purging of the refrigerant gas system;*
- *There is continuity of grounding.*

Thank you

Dear Customer,

Thank you for your purchase and for your confidence in our products.

These are the result of many years of research in the field of design and production of heat pumps for swimming pools. Our aim is to provide you with an exceptional high performance quality product.

We have produced this manual with the utmost care so that you get maximum benefit from your heat pump.





PLEASE READ CAREFULLY.



**These installation instructions are an integral part of the product.
They must be given to the installer and retained by the user.
If the manual is lost, please consult the website:**

www.Irrijardin.fr

The instructions and recommendations contained in this manual should be read carefully and understood since they provide valuable information concerning the heat pump's safe handling and operation. **Keep this manual in an accessible place for easy future reference.**

Installation must be carried out by a qualified professional person in accordance with current regulations and the manufacturer's instructions. An installation error may cause physical injury to persons or animals as well as mechanical damage for which the manufacturer can under no circumstances be held responsible.

After unpacking the heat pump, please check the contents in order to report any damage.

Prior to connecting the heat pump, ensure that the information provided in this manual is compatible with the actual installation conditions and does not exceed the maximum limits authorised for this particular product.

In the event of a defect and/or malfunction of the heat pump, the electricity supply must be disconnected and no attempt made to repair the fault.

Repairs must be undertaken only by an authorised technical service organisation using original replacement parts. Failure to comply with the above-mentioned clauses may have an adverse effect on the heat pump's safe operation.

To guarantee the heat pump's efficiency and satisfactory operation, it is important to ensure its regular maintenance in accordance with the instructions provided.

If the heat pump is sold or transferred, always make sure that all technical documentation is transmitted with the equipment to the new owner.

This heat pump is designed solely for heating a swimming pool. Any other use must be considered as being inappropriate, incorrect or even hazardous.

Any contractual or non-contractual liability of the manufacturer/distributor shall be deemed null and void for damage caused by installation or operational errors, or due to non-compliance with the instructions provided in this manual or with current installation norms applicable to the equipment covered by this document.

Contents

1.	General	6
1.1	General Terms of Delivery	6
1.2	Safety instructions	6
1.3	Water treatment	7
2.	Description	8
2.1	Package contents	8
2.2	General characteristics	8
2.3	Technical specifications	9
2.4	Unit dimensions	10
2.5	Exploded view	11
3.	Installation	12
3.1	Pre-requirements	12
3.2	Location	12
3.3	Installation layout	13
3.4	Connecting the condensation draining kit	13
3.5	Installing the unit on noise-damping supports	13
3.6	Hydraulic connection	14
3.7	Electrical installation	16
3.8	Electrical connection	17
4.	Use	18
4.1	Remote control	18
4.2	Mise en route et verrouillage	19
4.3	Operating mode selector	20
4.4	LED Technology	20
4.5	Forced de-icing function	19
4.6	Status values and parameter Query	21
4.7	WiFi Pairing and using	23
4.8	Setting up the app	24
4.9	Pairing the heat pump	26
4.10	Controlling	27
5.	Operation	28
5.1	Operation	28
5.2	Servo-control of circulating pump	28
5.3	Using the pressure gauge	29
5.4	Antifreeze protection	29
6.	Maintenance and servicing	30
6.1	Maintenance and servicing	30
6.2	Winter storage	30
7.	Repairs	31
7.1	Breakdowns and faults	31
7.2	Winter storage	32
8.	Recycling	33
8.1	Recycling the heat pump	33
9.	Warranty	34
9.1	General warranty conditions	34
10.	Appendices	35
10.1	Wiring diagrams	35

1. General

1.1 General Terms of Delivery

All equipment, even if shipped 'free of carriage and packing', is dispatched at the consignee's own risk

The person responsible for receiving the equipment must carry out a visual inspection to identify any damage to the heat pump during transport (refrigerant system, body panels, electrical control box, frame). He/she must note down on the carrier's delivery note any remarks concerning damage caused during transport and confirm them to the carrier by registered letter within 48 hours.

The equipment must always be stored and transported vertically on a pallet and in its original packaging. If



it is stored or transported horizontally, wait at least 24 hours before switching it on.

1.2 Safety instructions



WARNING: Please read carefully the safety instructions before using the equipment. The following instructions are essential for safety so please strictly comply with them.

During installation and servicing

Only a qualified person may undertake installation, start-up, servicing and repairs, in compliance with current standards.

Before operating or undertaking any work on the equipment (installation, commissioning, usage, servicing), the person responsible must be aware of all the instructions in the heat pump's installation manual as well as the technical specifications.

Under no circumstances install the equipment close to a source of heat, combustible materials or a building's air intake.

If installation is not in a location with restricted access, a heat pump protective grille must be fitted.

To avoid severe burns, do not walk on pipework during installation, repairs or maintenance.

To avoid severe burns, prior to any work on the refrigerant system, turn off the heat pump and wait several minutes before placing temperature and pressure sensors.

Check the refrigerant level when servicing the heat pump.

Check that the high and low pressure switches are correctly connected to the refrigerant system and that they turn off the electrical circuit if tripped during the equipment's annual leakage inspection.

Check that there is no trace of corrosion or oil stains around the refrigerant components.

1. General

During use

To avoid serious injuries, never touch the fan when it is operating.

Keep the heat pump out of the reach of children to avoid serious injuries caused by the heat exchanger's blades.

Never start the equipment if there is no water in the pool or if the circulating pump is stopped.

Check the water flow rate every month and clean the filter if necessary.

During cleaning

Switch off the equipment's electricity supply.

Close the water inlet and outlet valves.

Do not insert anything into the air or water intakes or outlets.

Do not rinse the equipment with HP water.

During repairs

Carry out work on the refrigerant system in accordance with current safety regulations.

Brazing should be performed by a qualified welder.

When replacing a defective refrigerant component, use only parts certified by our technical department.

In case of piping replacement, only copper tubing conforming to country standards may be used for troubleshooting.

When pressure-testing to detect leaks:

To avoid the risks of fire or explosion, never use oxygen or dry air.

Use dehydrated nitrogen or a mixture of nitrogen and refrigerant.

The low and high side test pressure must not exceed 42 bar.

1.3 Water treatment

Irripool heat pumps for swimming pools can be used with all types of water treatment systems.

Nevertheless, it is essential that the treatment system (chlorine, pH, bromine and/or salt chlorinator metering pumps) is installed after the heat pump in the hydraulic circuit.

To avoid any deterioration to the heat pump, the water's pH must be maintained between 6.9 and 8.0.

2. Description

2.1 Package contents

- ✓ Heat pump IR ALPHA INV Expert
- ✓ 2 hydraulic inlet/outlet connectors (50mm diameter)
- ✓ This installation and user manual
- ✓ Condensation draining kit
- ✓ **Winter storage cover**
- ✓ **4 anti-vibration pads (fastenings not supplied)**

2.2 General characteristics

A Irripool heat pump has the following features:

- ◆ CE certification and complies with the RoHS European directive.
- ◆ High performance with up to 80% energy savings compared to a conventional heating system.
- ◆ Clean, efficient and environmentally friendly R32 refrigerant.
- ◆ Reliable high output leading brand compressor.
- ◆ Wide hydrophilic aluminium evaporator for use at low temperatures.
- ◆ User-friendly intuitive remote control.
- ◆ Heavy duty ABS shell, anti-UV treated and easy to maintain.
- ◆ Designed to be silent.
- ◆ Dual antifreeze system to avoid frost damage:
 - Revolutionary exchanger with patented antifreeze system.
 - A smart monitoring system to preserve the pipework and liner without emptying the pool in winter.

2. Description

2.3 Technical specifications

		Irrijardin IR ALPHA INV Expert		
Test conditions		70	100	150
Air ⁽¹⁾ 26°C Water ⁽²⁾ 26°C INVERTER MODE	Heating power (kW)	9.5~1.93	13.5~2.53	19.5~3.69
	Consumption (kW)	1.513~0.135	2.113~0,176	3.056~0.263
	COP (Coeff. of performance)	14.30~6.28	14.33~6.39	14~6.38
Air ⁽¹⁾ 15°C Water ⁽²⁾ 26°C INVERTER MODE	Heating power (kW)	7.05~1.41	9.98~2.01	15~2.95
	Consumption (kW)	1.382~0.172	1.953~0.245	2.953~0.361
	COP (Coeff. of performance)	8.16~5.1	8.2~5.11	8.17~5.08
Air ⁽¹⁾ 35°C Water ⁽²⁾ 27°C	Cooling capacity (kW)	5.01~1.59	6.59~2.13	10.19~3.39
	Consumption (kW)	1.43~0.335	1.89~0.445	2.93~0.713
	Avg. EER (Energy Efficiency Ratio)	4.75~63.5	4.79	4.75~3.45
Maximum power (kW)		1.9	3.2	4.7
Maximum current (A)		8.26	13.91	20.43
Electricity supply		220~240V / 50Hz		
Protection		IPX4		
Heating temperature range		15°C~40°C		
Cooling temperature range		8°C~28°C		
Operating temperature range		-15°C~43°C		
Unit dimensions L x W x H (mm)		520*520*720		660*660*800
Unit weight (kg)		45	49	62
Sound pressure level at 1 m (dBA) ⁽³⁾		42~52	42~53	45~55
Sound pressure level at 10 m (dBA) ⁽³⁾		23~30	23~30	25~32
Hydraulic connection (mm)		PVC 50mm		
Heat exchanger		Cuve PVC et Serpentin Titane		
Min. / Max. water flow rate (m ³ /h)		3	4,3	6,4
Compressor		Mitsubishi		
Compressor type		Rotary		
Refrigerant		R32		
Load loss (mCE)		0.9	1	1.1
Max. pool volume (m ³) ⁽⁴⁾		35 to 45	50 to 70	75 to 105
Remote control		Écran de contrôle LCD		
Mode		Chauffage, refroidissement, Auto / Silent, Eco Boost		

The technical specifications of our heat pumps are provided for information purposes only. We reserve the right to make changes without prior notice.

¹ Ambient air temperature

² Initial water temperature

³ Noise at 1 m, at 4 m and at 10 m in accordance with Directives EN ISO 3741 and EN ISO 354

⁴ Calculated for an in-ground private swimming pool covered with a bubble cover.

2. Description

2.4 Unit dimensions

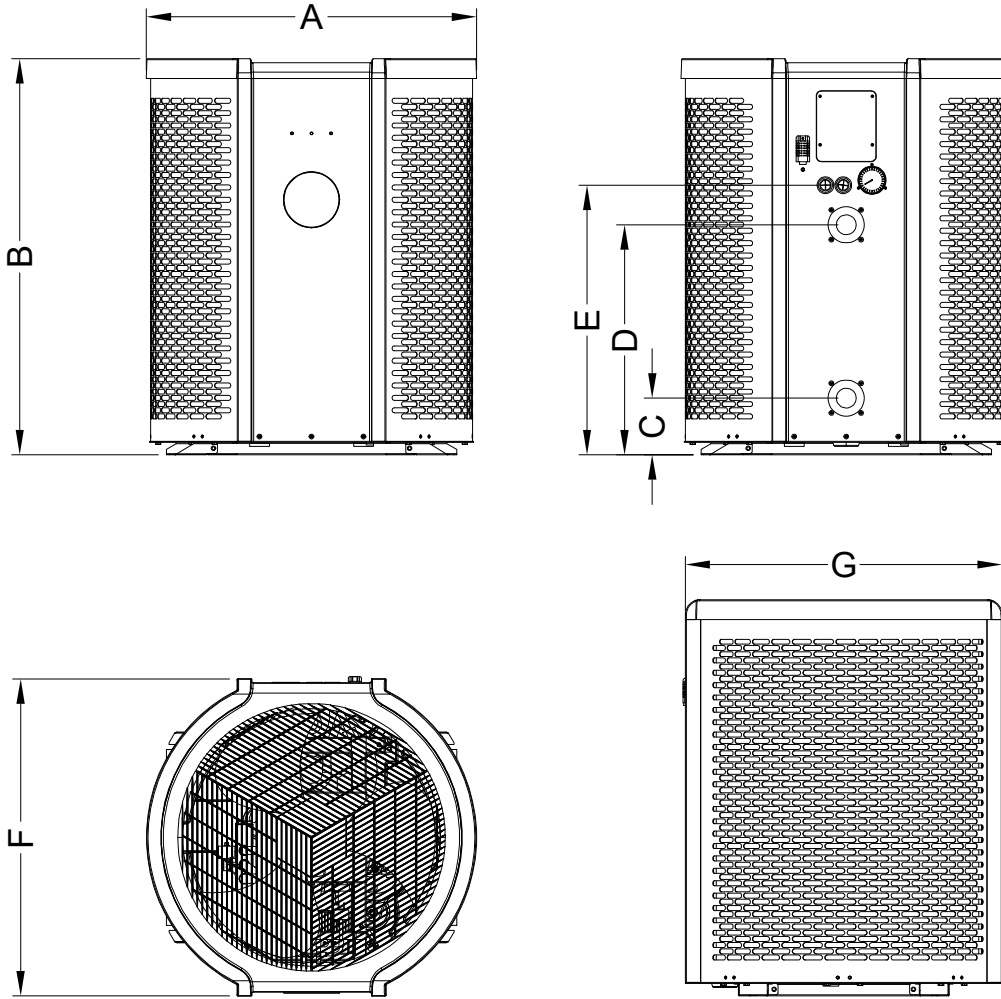

Dimensions en mm

Modèle	IR ALPHA INV Expert 70	IR ALPHA INV Expert 100	IR ALPHA INV Expert 150
A	509	509	667
B	720	720	800
C	110	110	120
D	360	420	470
E	498	498	555
F	506	506	645
G	506	506	645

2. Description

2.5 Exploded view

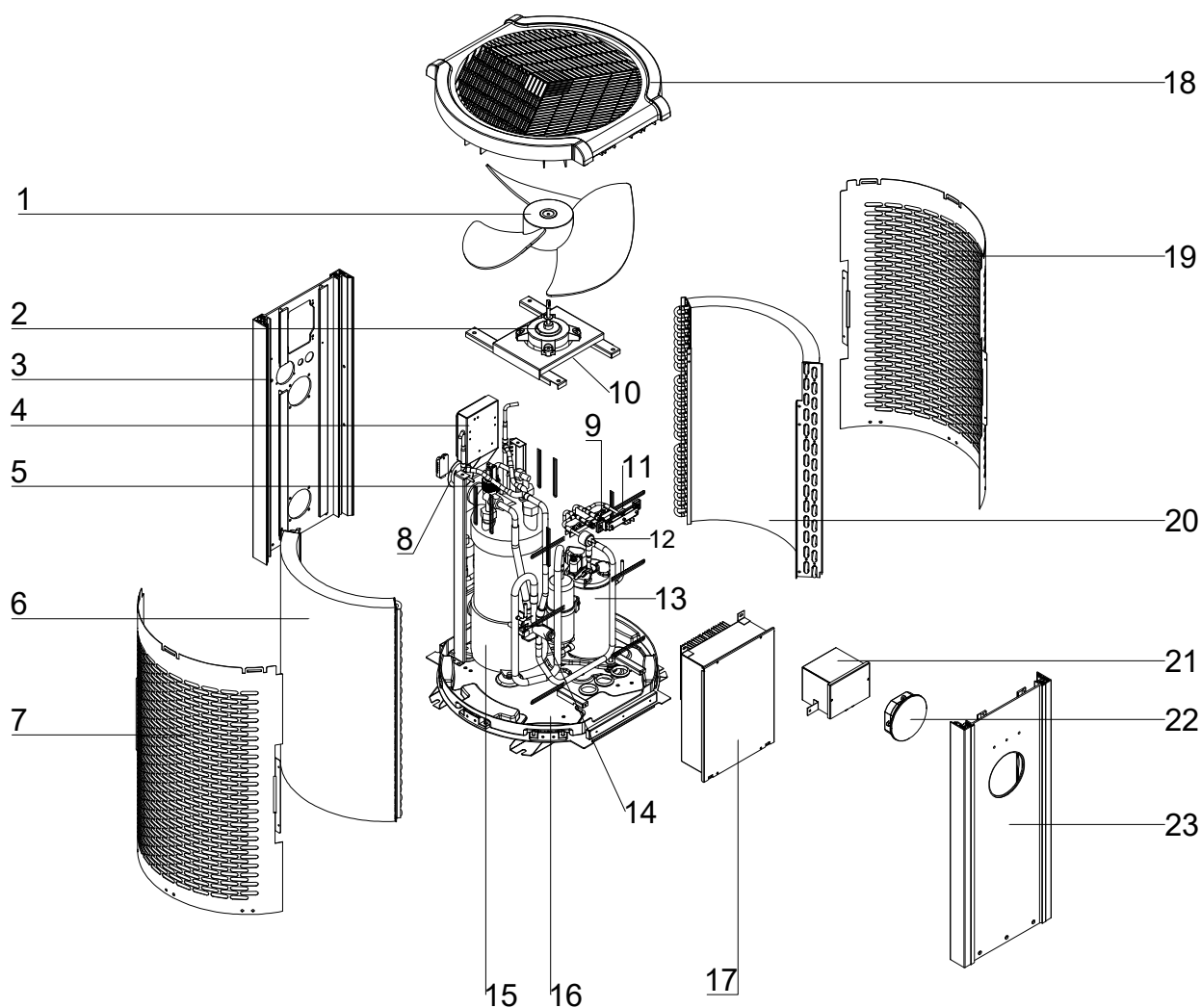

- | | |
|------------------------------|----------------------------|
| 1. Fan blade | 13. Compressor |
| 2. Fan motor | 14. 4-way valve |
| 3. Back panel | 15. Heat exchanger |
| 4. Electrical terminal block | 16. Mounting frame |
| 5. Water Flow Switch | 17. Logic board box |
| 6. Left Evaporator | 18. Top panel |
| 7. Left side panel | 19. Right side panel |
| 8. Pressure gauge | 20. Right evaporator |
| 9. Needle valve | 21. Electrical control box |
| 10. Fan support | 22. Control panel |
| 11. low pressure switch | 23. Front panel |
| 12. High pressure switch | |

3. Installation



WARNING: Installation must be carried out by a qualified engineer.

This section is provided for information purposes only and must be checked and adapted if necessary according to the actual installation conditions.

3.1 Pre-requirements

Equipment necessary for the installation of your heat pump:

Power supply cable suitable for the unit's power requirements.

A *By-Pass* kit and an assembly of PVC tubing suitable for your installation as well as stripper, PVC adhesive and sandpaper.

A set of wall plugs and expansion screws suitable to attach the unit to your support.

We recommend that you connect the device to your installation using rigid PVC pipes in order to reduce the propagation of vibrations.

Suitable fastening studs may be used to raise the unit.

3.2 Location

Please comply with the following rules concerning the choice of heat pump location.

1. The unit's future location must be easily accessible for convenient operation and maintenance.
2. It must be installed on the ground, fixed ideally on a level concrete floor. Ensure that the floor is sufficiently stable and can support the weight of the unit.
3. A water drainage device must be provided close to the unit in order to protect the area where it is installed.
4. If necessary, the unit may be raised by using suitable mounting pads designed to support its weight.
5. Check that the unit is properly ventilated, that the air outlet is not facing the windows of neighbouring buildings and that the exhaust air cannot return. In addition, provide sufficient space around the unit for servicing and maintenance operations.
6. The unit must not be installed in an area exposed to oil, flammable gases, corrosive products, sulphurous compounds or close to high frequency equipment.
7. To prevent mud splashes, do not install the unit near a road or track.
8. To avoid causing nuisance to neighbours, make sure the unit is installed so that it is positioned towards the area that is least sensitive to noise.
9. Keep the unit as much as possible out of the reach of children.

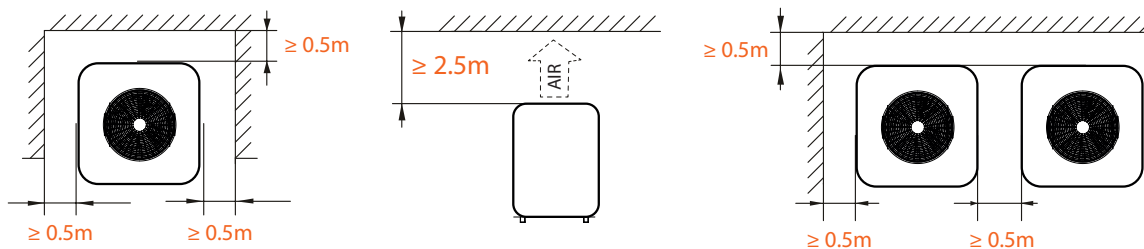

Dimensions in mm.

Place nothing less than one metre in front of the heat pump.
Leave 50 cm of empty space around the sides and rear of the heat pump.

Do not leave any obstacle above or in front of the unit!

3. Installation

3.3 Installation layout

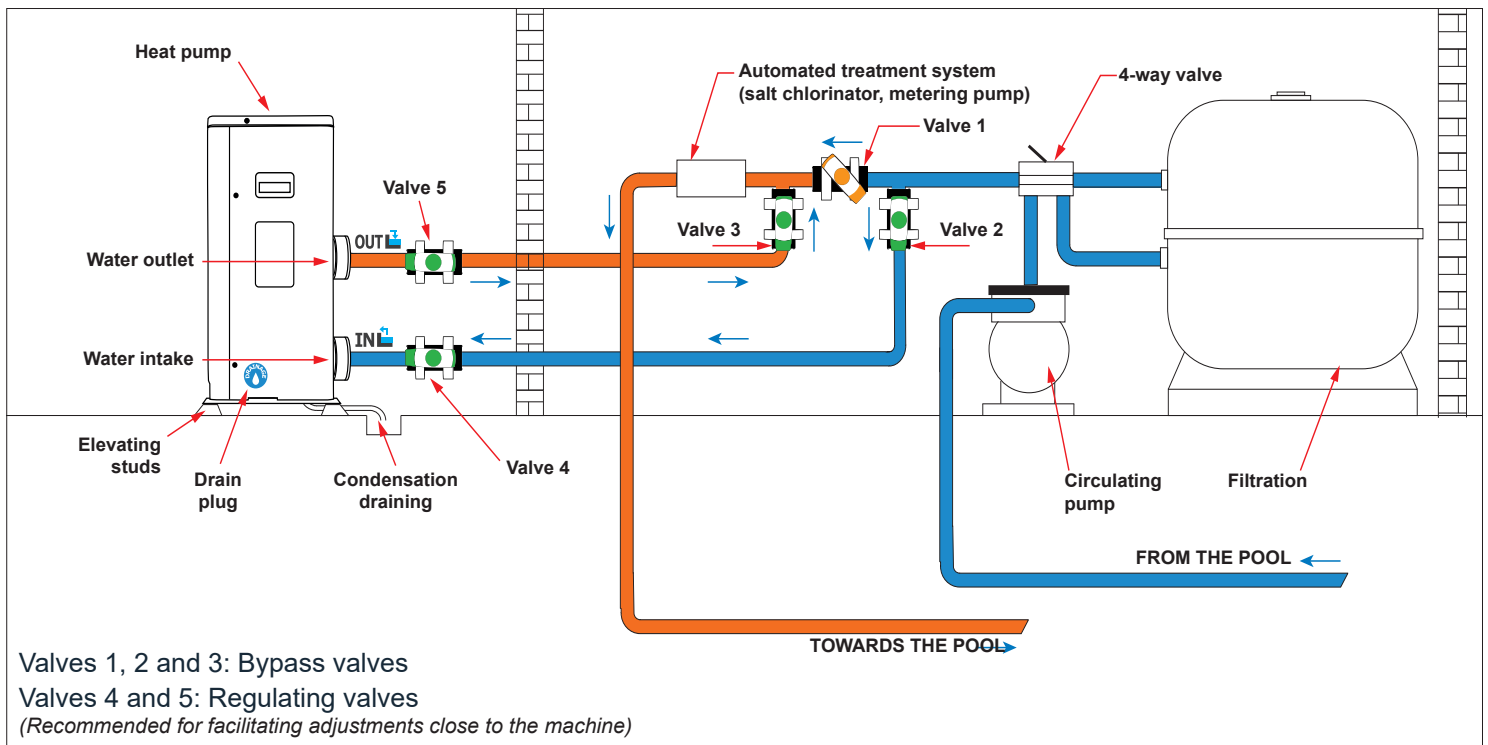

Key



Half-open valve



Open valve

3.4 Connecting the condensation draining kit

While operating, the heat pump is subject to condensation. This will result in a more or less large run-off of water, depending on the degree of humidity. To channel this flow, we recommend that you install the condensation drainage kit.

How do you install the condensation drainage kit?

Install the heat pump, raising it at least 10 cm with solid water-resistant pads, then connect the drainage pipe to the opening located under the pump.

3.5 Installing the unit on noise-damping supports

In order to minimise the noise pollution associated with heat pump vibrations, it can be positioned on vibration absorbing pads.

To do this, you simply have to position a pad between each of the unit's feet and its support, and then fix the heat pump to the support with suitable screws.

3. Installation



WARNING: Installation must be carried out by a qualified engineer.

This section is provided for information purposes only and must be checked and adapted if necessary according to the actual installation conditions.

3.6 Hydraulic connection

By-Pass assembly

The heat pump must be connected to the pool by means of a By-Pass assembly.

A By-Pass is an assembly consisting of 3 valves that regulate the flow circulating in the heat pump. During maintenance operations, the By-Pass permits the heat pump to be isolated from the system without interrupting your installation.

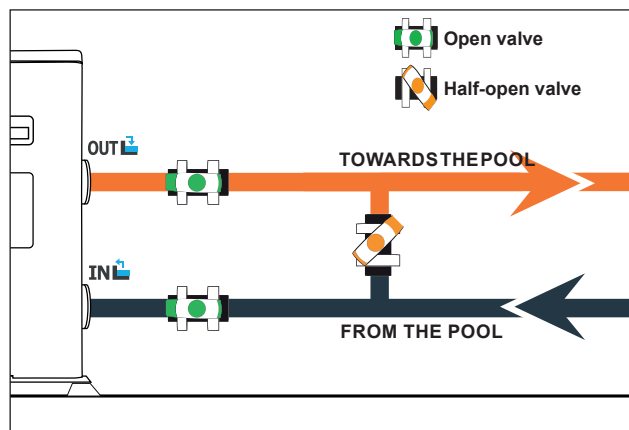

Making a hydraulic connection with the By-Pass kit



WARNING: Do not run water through the hydraulic circuit for 2 hours after applying the adhesive.

Step 1: Take the necessary steps to cut your pipes.

Step 2: Make a straight perpendicular cut through the PVC pipes with a saw.

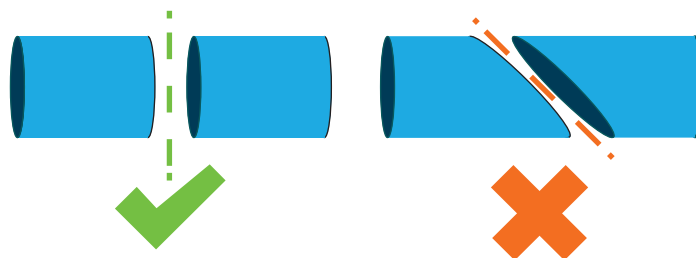

Step 3: Assemble your hydraulic circuit without connecting it in order to check that it perfectly fits your installation, then dismantle the pipes to be connected.

Step 4: Chamfer the ends of the cut pipes with sandpaper.

Step 5: Apply stripper to the ends of the pipes to be connected.

Step 6: Apply the adhesive in the same place.

Step 7: Assemble the pipes.

Step 7: Clean off any adhesive remaining on the PVC.

Step 8: Leave to dry for at least 2 hours before putting the hydraulic circuit into water.

3. Installation

By-Pass assembly for one heat pump

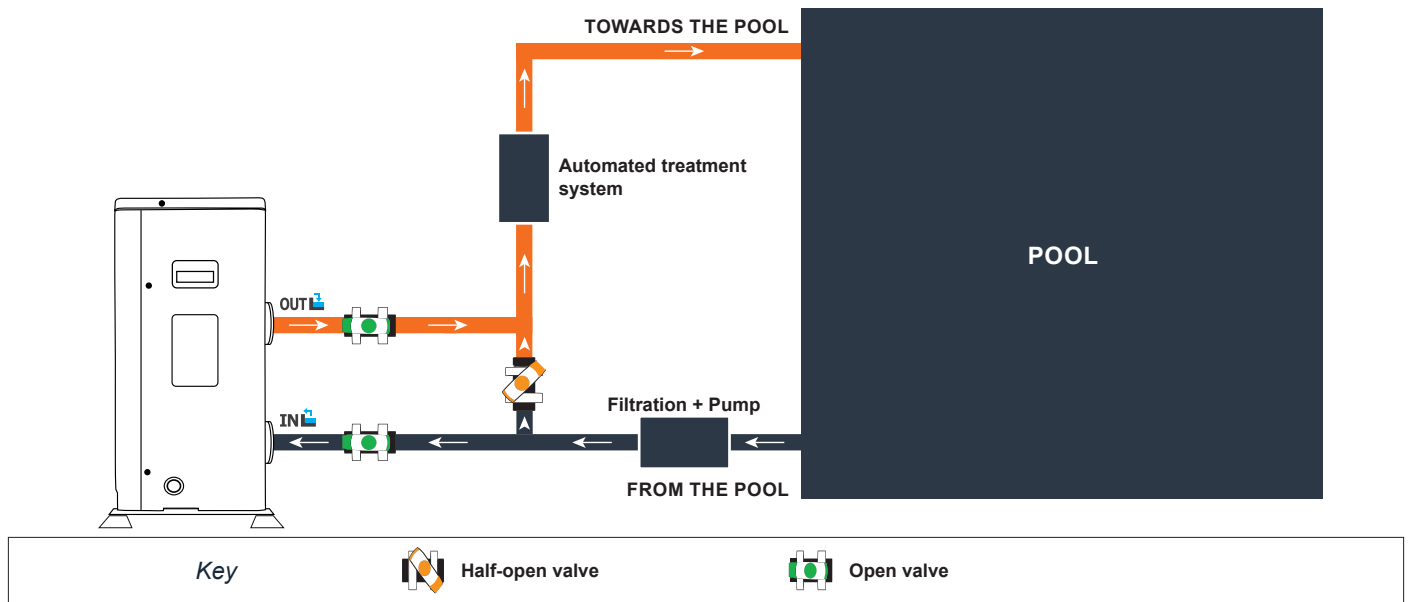

By-Pass assembly for more than one heat pump

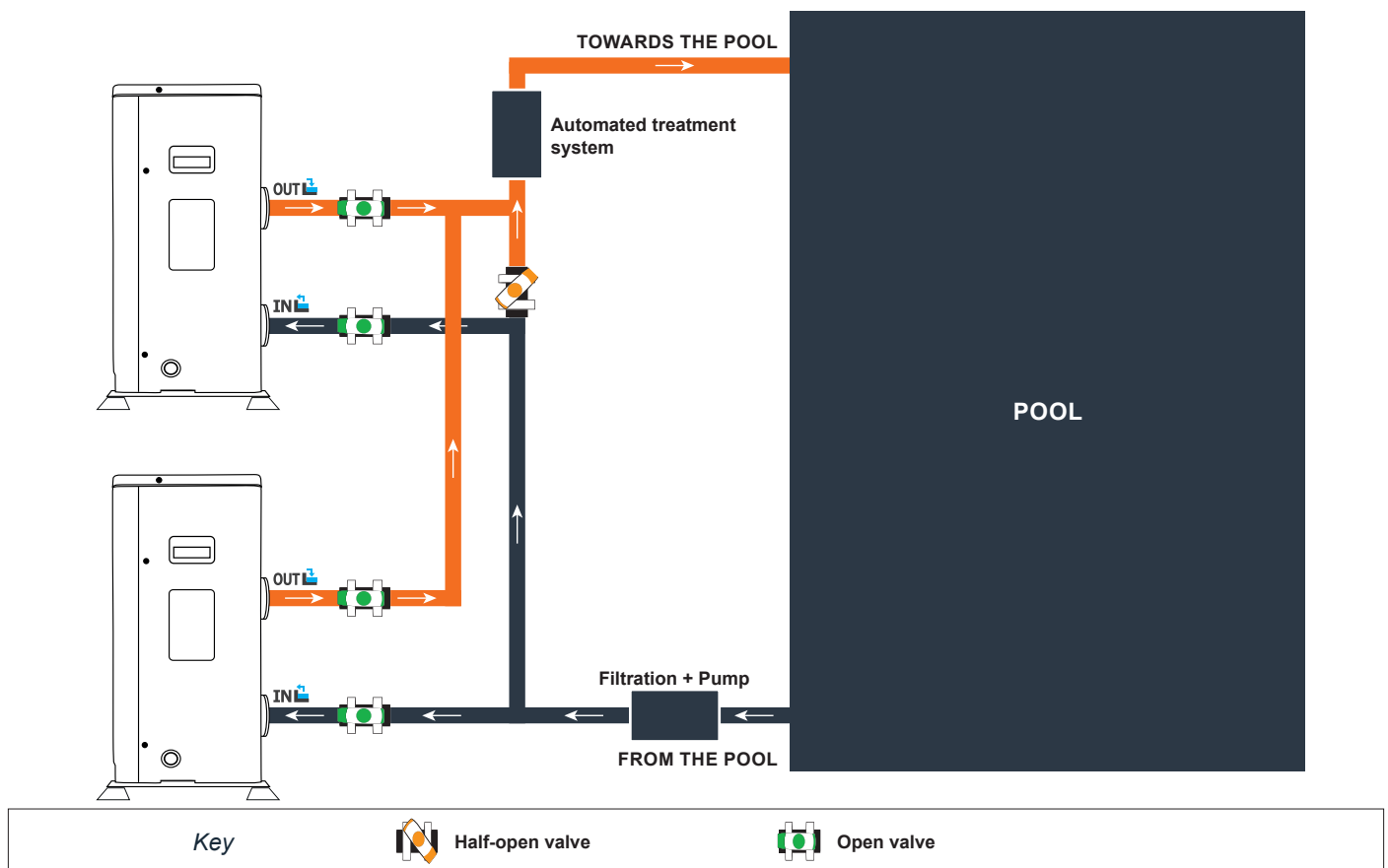

The filter located upstream of the heat pump must be regularly cleared so that the water in the system is clean, thus avoiding the operational problems associated with dirt or clogging in the filter.

3. Installation



WARNING: Installation must be carried out by a qualified engineer.

This section is provided for information purposes only and must be checked and adapted if necessary according to the actual installation conditions.

3.7 Electrical installation

To function safely and maintain the integrity of your electrical system, the unit must be connected to a general electricity supply in accordance with the following regulations:

Upstream, the general electricity supply must be protected by a 30 mA differential switch.

The heat pump must be connected to a suitable D-curve circuit breaker (see table below) in accordance with current standards and regulations in the country where the system is installed.

The electricity supply cable must be adapted to match the unit's rated power and the length of wiring required by the installation (see table below). The cable must be suitable for outdoor use.

For a three-phase system, it is essential to connect the phases in the correct sequence. If the phases are inverted, the heat pump's compressor will not work.

In places open to the public, it is mandatory to install an emergency stop button close to the heat pump.

Models	Electricity supply	Max. current	Cable diameter	Protection Thermal-magnetic (D curve) protection
IR ALPHA INV Expert 70	Singlephase 230V~50Hz	8.26 A	RO2V 3x2,5 mm ²	10 A
IR ALPHA INV Expert 100		13.91 A	RO2V 3x2,5 mm ²	16 A
IR ALPHA INV Expert 150		20.43 A	RO2V 3x4 mm ²	20 A

¹ Cable cross-section suitable for max. length 10 metres. For longer than 10 metres, consult an electrician.

3. Installation

3.8 Electrical connection



WARNING: The heat pump's power supply MUST be disconnected before any operation.

Please comply with the following instructions to electrically connect the heat pump.

Step 1: Detach the electrical side panel with a screwdriver to access the electrical terminal block.

Step 2: Insert the cable into the heat pump unit by passing it through the opening provided for that purpose.

Step 3: Connect the power supply cable to the terminal block in accordance with the diagram below.

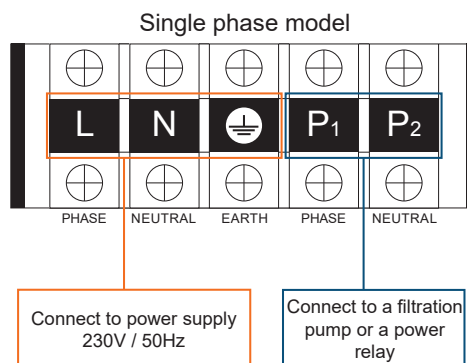

Step 4: Carefully close the heat pump panel.

Servo-control of circulating pump

Depending on the type of installation, you can also connect a circulating pump to terminals P1 and P2 so that this operates in tandem with the heat pump.



WARNING: Servo-control of a pump whose power exceeds 5A (1000W) requires the use of a power relay.

4. Use

4.1 remote control

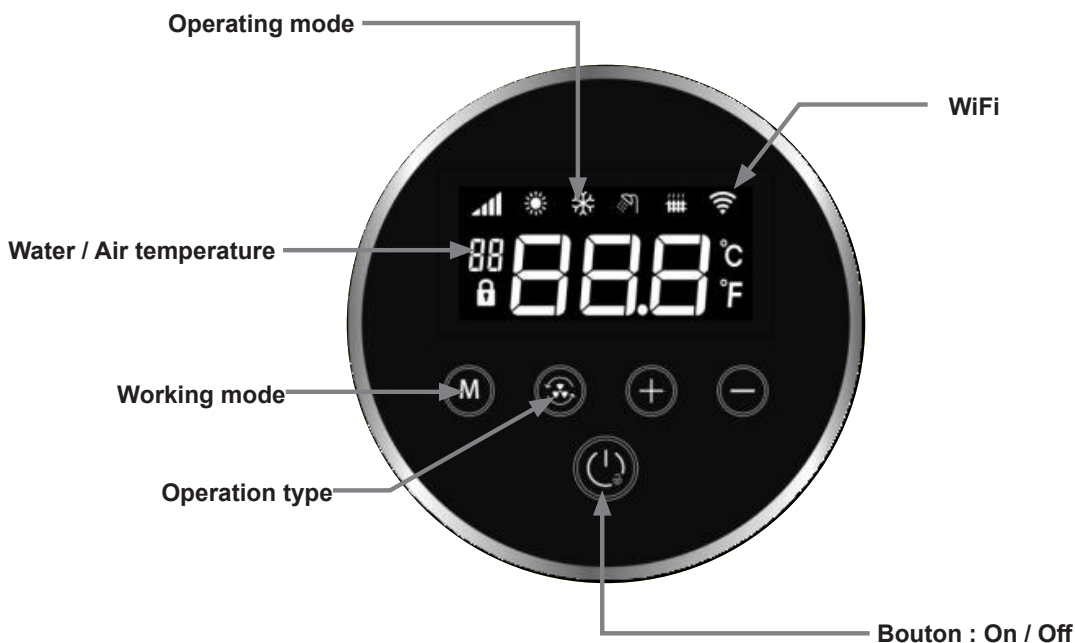

Before you start, make sure the filtration pump is running and water is flowing through the heat pump.

 Before setting your target temperature, you must first choose the operating mode of your heat pump:

Other indications of the control unit



This icon represents Boost mode



This icon represents Smart mode.



Change from C ° to F °

Hold  and  for 5 seconds to toggle between Celcius and Fahrenheit display.

4. Use







4.2 Operating mode selector

Press the button  to switch the heat pump on or off. This button is also used to return to the main interface.

When the heat pump is in operation, press the button  for 5 seconds to lock or unlock the housing. (The lock is activated automatically after 60 seconds of inactivity). When the case is locked, the logo  appears.

4.3 Operating mode selector

Press the button  to change the operating mode :

- | | | |
|---------------------------------|---|--|
| heating |  | SILENT Heating mode: Choose this heating mode so that the heat pump operates silently. |
| |  | ECO Heating mode: Choose this heating mode for the heat pump to operate in a conventional manner. |
| |  | BOOST heating mode: Choose this heating mode so that the heat pump quickly heats the water in your pool. |
| Maintaining the set temperature |  | Auto mode: The heat pump intelligently chooses the most appropriate operating mode according to the setpoint temperature. |
| Cooling |  | SILENT Cooling mode: Choose this cooling mode for the heat pump to operate silently. |
| |  | ECO Cooling mode: Choose this cooling mode so that the heat pump operates in a conventional manner. |
| |  | BOOST Cooling mode: Choose this cooling mode for the heat pump to operate in a classic way. |

4.4 intelligent LED technology



The ambient LEDs integrated into the front of your heat pump provide you with instant information on the operating status of your heat pump. :

Blue: your pool is heating.

Green: your pool has reached its set temperature.

Red: Your intervention is required.

4.5 Force defrost the pump

Hold  and  for 5 seconds to force the pump to defrost, the symbol  flashes.

4. Use

4.6 Parameters

Main parameters table

To enter the main parameters, hold the  button for 3s.

N°	Description	Valeur par défaut	Variation
C1	Compressor 1 frequency	0~120	Hz
C3	Inlet water temp.	-99~999	°C
C4	Coil temp.	-99~999	°C
C5	Exhaust temp.	-99~999	°C
C6	Suction temp.	-99~999	°C
C7	Inter coil temp.	-99~999	°C
C8	Ambient temp.	-99~999	°C
C11	Outlet water temp.	-99~999	°C
C17	Step of the main valve	0~999	p
C25	Driver AC voltage	0~999	V
C26	Driver AC current	0~99.9	A
C27	Driver DC voltage	0~999	V
C28	Driver Phase current	0~99.9	A
C29	Driver IPM temp.	-99~999	°C
C30	Driver DC fan 1 speed	0~999	Tr/min

4. Use

System parameters table

To enter the system parameters, hold the  button for 3s to enter the main parameters, then press  again for 3s and enter the code 184.

N°	Description	Valeur par défaut	unit	Defaut
F1	Heating setting temp.	20~80	°C	27
F2	Cooling setting temp.	5~30	°C	27
F4	Automatic mode setting temp.	10~60	°C	27
F5	Linkage switch enabling	0~2	-	2
F6	Heating return difference temp.	0~10	°C	2
F7	Cooling return difference temp.	0~10	°C	2
F9	Automatic return difference temp.	0~10	°C	2
F10	Heating upper limit temp.	20~80	°C	40
F11	Cooling lower limit temp.	5~30	°C	10
F13	Emergency stop return difference temp.	1~6	°C	2
F14	Fast start-stop cycle	10~90	s	30
F15	Regular start-stop cycle	10~250	s	60
F16	Bit0:Three phase detection enabling(0: close;1:open); Bit1:Four-way valve mode(0:Power ups when cooling;1:Power ups when heating; Bit2:Shield anti-freezing(0:Allow anti-freezing;1:Forbid anti-freezing) Detail behind the table	0~7	-	0
F17	Fan type: 0:AC single wind speed; 1:Double wind speed; 3:DC single fan; 4:DC double fan; 5:HP DC single fan; 6:HP DC double fan	0~6	-	0
F18	Model selection: 1: Heating&Cooling; 3: Automatic+Heating&Cooling; 4: Hot water; 5: Heating; 6: Cooling; 7: Heating&Cooling+ Heating energy conservation ; 8: Automatic+Heating&Cooling+ Heating energy conservation	1~8	-	3
F19	Bit0: Slave parameter synchronize (0: Common parameters synchronize;1 : All parameters synchronize); Bit1:Simultaneous defrosting for linked units (0 : Out of synchronize ;1:Defrosting synchronize); Bit2:Synchronization of slave unit parameters(0 : Valid;1 : Invalid);	0~7	-	0
F20	Water pump operation mode 0:Keep running when constant temperature shutdown; 1:Turn off after constant temperature shutdown 2min; 2: Intermittent operation; 3:Keep running when constant temperature shutdown when use the host water pump together; 4:Turn off after constant temperature shutdown 2min when use the host water pump together; 5:Intermittent operation when use the host water pump together	0~5	-	0
F21	Water pump interval running time	0~120	min	5
F22	Start electric auxiliary heater ambient temp.	-50~30	°C	-20
F23	Temp. compensation value	-10~10	°C	0
F24	Remote monitoring address (Communication address for PC port remote monitoring)	0~255	-	0
F25	Maximum operating frequency of the compressor	0~120	Hz	85
F26	Compressor model(Frequency conversion)/Over current protection value(Frequency constant)	0~999	-	2
F27	Mode selection: bit0-bit1 : 0: Energy saving mode ; 1: Enhanced mode ; 2: Silent mode bit2:1 : Test mode	0~7	-	0

4. Use

F29	Manual opening step of the main valve	0~500	P	0
F33	Compressor manual frequency(Frequency conversion)/(Constant frequency invalid)	0~120	Hz	0
F35	DC fan1manual speed*10(Frequency conversion)/(Constant frequency invalid)	0~200	-	0
F40	Coil temp. when allow defrosting	-30~15	°C	-10
F41	Coil temp. when exit defrosting	0~40	°C	15
F42	Ambient temp. when allow defrosting	-30~30	°C	10
F43	Setting difference between ambient temp. and coil temp.when start defrosting	0~20	°C	10
F44	Temp.difference between ambient and fin when early start defrosting	0~20	°C	6
F45	Compressor operating cycle when enter defrost	1~240	min	40
F46	Running time of defrosting, 0 represent removal defrosting function	0~99	min	8
F47	Exhaust sensor type(0:50K-20K 1:5K-5.1K 2:5K-20K)	0~2	-	0
F48	Compressor frequency when enter the defrosting	0~50	Hz	30
F50	"Main valve control mode 1:Automatic control; 2 : Low pressure(Reserved); 3 : Exhaust overheat degree ; 4 : Return overheat degree; "	1~5	-	4
F51	Main valve adjustment cycle	10~120	s	60
F52	Overheat of main valve A coefficient	0~5050	-	508
F53	Ambient temp. when open the EVI(cooling) (More than 60 show shut down EVI)	0~60	°C	60
F55	Main valve target overheat degree(heating)	-10~10	°C	3
F56	Main valve target overheat degree(cooling)	-10~15	°C	0
F57	Min. opening step of the main valve(cooling)	0~480	P	100
F58	Min. opening step of the main valve(heating)	0~480	P	100
F59	EVI exhaust temp.(cooling)	0~120	°C	70
F78	Extended parameter-parameter number	0~9999	-	0
F79	Extended parameter- setting data	0~9999	-	0
F80	Extended parameter- min. setting data	0~9999	-	0
F81	Extended parameter- max. setting data	0~9999	-	0

4. Use

4.7 Downloading & Installing the «Smart Life» app

About the Smart Life app:

You'll need to create a «Smart Life» account to control your heat pump remotely.

The «Smart Life» app lets you control your home appliances from anywhere. You can add and control multiple devices at once.

- Also compatible with Amazon Echo and Google Home (depending on the country).
- You can share your devices with other Smart Life accounts.
- Receive real-time operational alerts.
- Create scenarios with several devices, depending on the app's weather data (geolocation required).

For more information, go to the «Help» section of the «Smart Life» app

The «Smart Life» app and services are provided by Hangzhou Tuya Technology. Irrijardin, owner and distributor of the Irripool brand, cannot be held responsible for the operation of the «Smart Life» app. Irrijardin has no visibility on your «Smart Life» account.

iOS :

Search for «Smart Life» in the App Store to download the app:

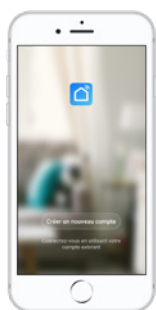

Check the compatibility of your phone and the version of your OS before installing the application

Android :

Search for «Smart Life» on Google Play to download the app :

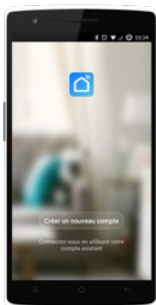

Check the compatibility of your phone and the version of your OS before installing the application

4. Use

4.8 Setting up the app



WARNING : Before you begin, make sure you have downloaded the «Smart Life» app, connected to your local WiFi network, and that your heat pump is electrically powered and running.

You'll need to create a «Smart Life» account to control your heat pump remotely. If you already have a Smart Life account, please log in and go directly to step 3.

Step 1 : Click on «Create new account» and choose to register by «Email» or «Phone,» where a verification code will be sent to you.

Enter your email address or phone number and click «Send verification code».

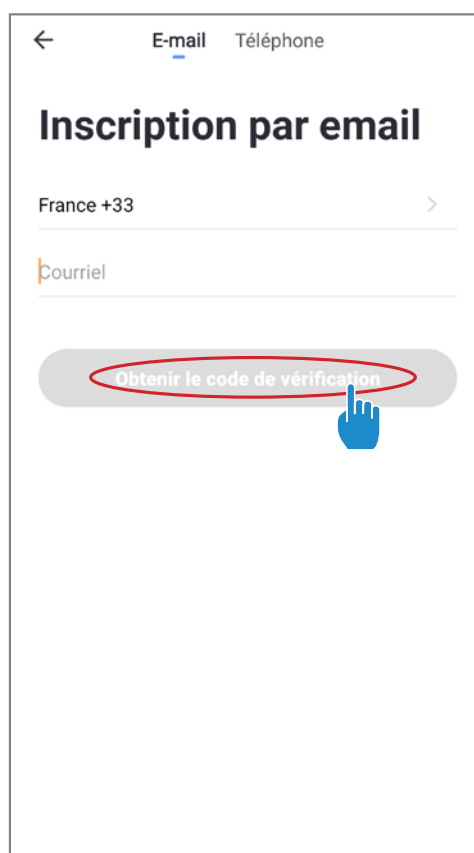
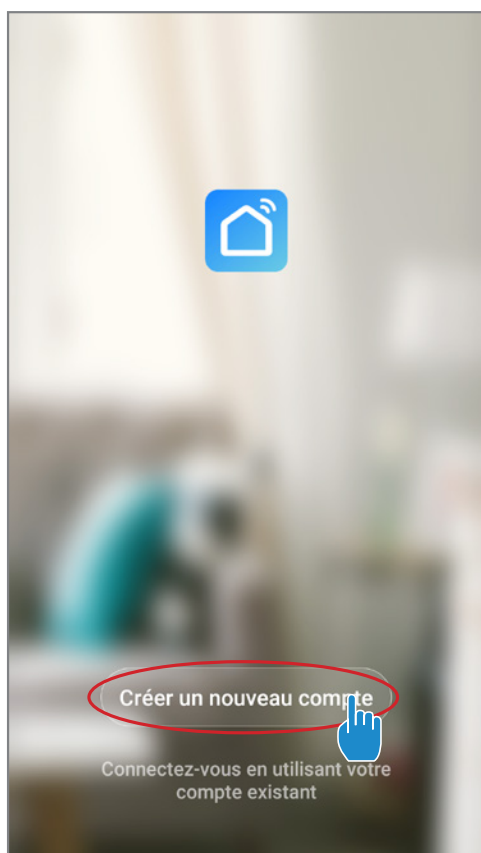

Step 2 : Enter the verification code received by email or phone to validate your account.

Congratulations! You are now part of the «Smart Life» community.

4. Use

Step 3 (Recommended): Add an object by clicking «...» and then «Add Object.» Enter its name («Pool» for example), then click «Done.»

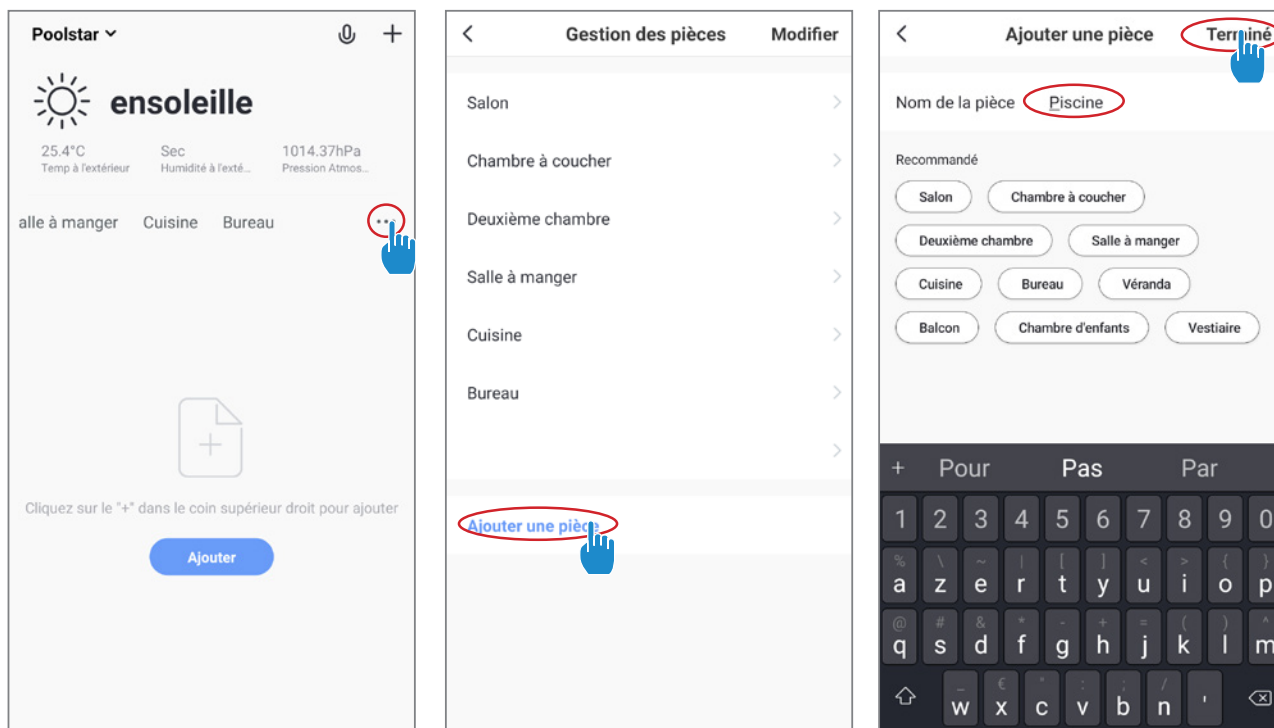

Step 4 : Now add a device to your «Pool»

Click «Add» or «+» and then «Large appliances...» followed by «Water heater.»

At this point, leave your smartphone on the «Add» screen and go to the pairing step for your control box.

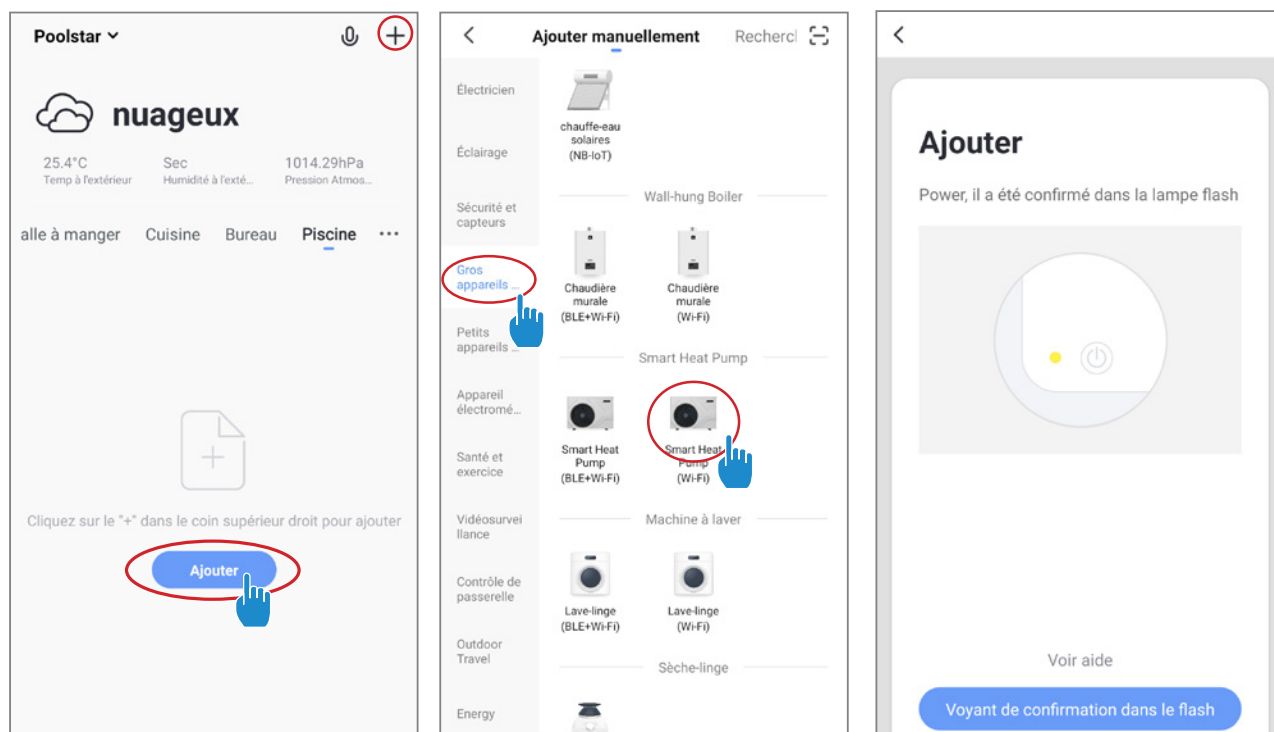

4. Use

4.9 Pairing the heat pump

EZ Mode

Step 1 : Now start the pairing.

Choose your home WiFi network, enter the WiFi password and press «Confirm».

Step 2 : Activate the pairing mode on your heat pump according to the following procedure:

The procedure depends on the model of your control box:



CAUTION The «Smart Life» application only supports 2.4GHz WiFi networks. If your WiFi network uses the 5GHz frequency, go to the interface of your home WiFi network to create a second 2.4GHz WiFi network (available for most Internet boxes, routers and WiFi access points).



Press + simultaneously for 5s, flashes quickly, the control unit is ready to be paired.

The pairing is successful, you can rename your Iripool heat pump then press «Done».

Congratulations, your heat pump can now be controlled from your smartphone.

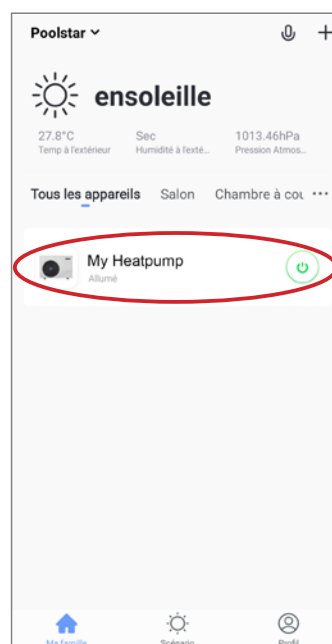
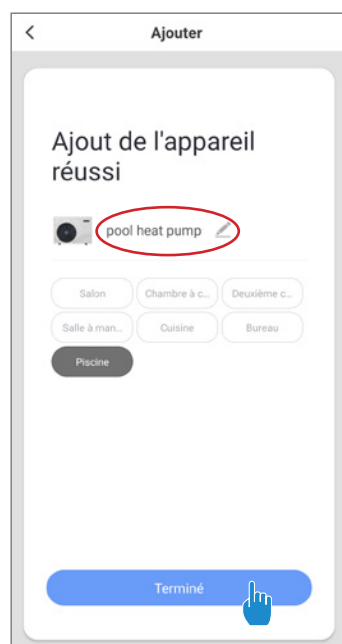

4. Use

4. Controlling

Interface

- 1 Current pool temperature
- 2 Temperature setpoint
- 3 Current operating mode
- 4 Switch the heat pump on/off
- 5 Change the temperature
- 6 Change the operating mode
- 7 Set the operating range



Configure the operating ranges for the heat pump

Step 1 : Create a schedule, choose the time, day(s) of the week(s), and the action (turn on or off) and save.

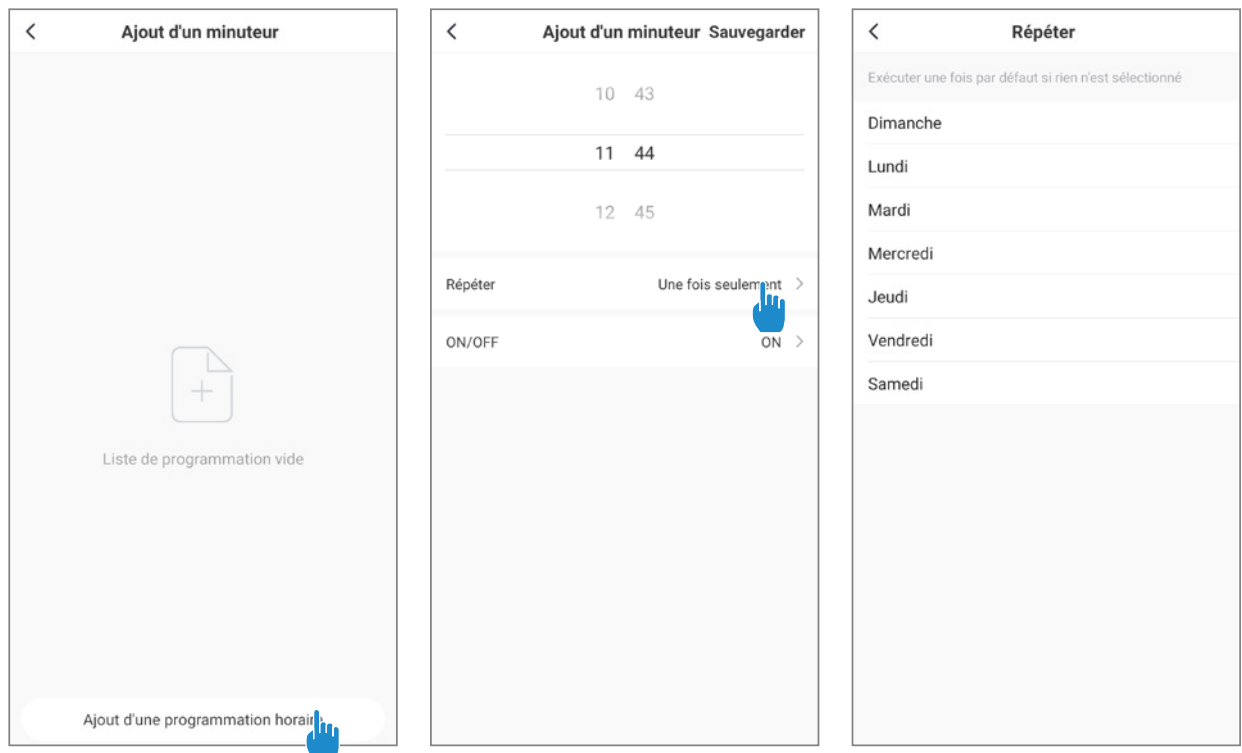

Step 2 : To delete a time slot, press on it and hold.

5. Operation

5.1 Operation

Conditions of use

For the heat pump to operate normally, the ambient air temperature must be between -10°C and 43°C.

Recommendations prior to start-up

Before activating the heat pump, please:

- ✓ Check that the unit is firmly secured and stable.
- ✓ Check that the gauge indicates a pressure greater than 80 psi.
- ✓ Check that the electrical wiring is properly connected to the terminals.
- ✓ Check the earthing.
- ✓ Check that the hydraulic connections are tight and that there is no leakage of water.
- ✓ Check that the water is circulating correctly in the heat pump and that the flow rate is adequate.
- ✓ Remove any unnecessary object or tool from around the unit.

Operation

1. Activate the unit's power supply protection (differential switch and circuit-breaker).
2. Activate the circulating pump if it is not servo-controlled.
3. Check the By-Pass opening and the control valves.
4. Activate the heat pump.
5. Adjust the remote control clock.
6. Select the required temperature by using one of the remote control's mode.
7. The heat pump's compressor will start up after a few moments.

All you have to do now is wait until the required temperature is reached.



WARNING: Under normal conditions, a suitable heat pump can heat the water in a swimming pool by 1°C to 2°C per day. It is therefore quite normal to not feel any temperature difference in the system when the heat pump is working.
A heated pool must be covered to avoid any loss of heat.

5.2 Servo-control of circulating pump

If you have connected a circulating pump to terminals P1 and P2, it is automatically electrically powered when the heat pump operates.

5. Operation

5.3 Using the pressure gauge

The gauge is for monitoring the pressure of the refrigerant contained in the heat pump. The values it indicates can vary considerably, depending on the climate, temperature and atmospheric pressure.

When the heat pump is in operation:

The gauge's needle indicates the refrigerant pressure.

Mean operating range between 250 and 450 PSI, depending on the ambient temperature and atmospheric pressure.

When the heat pump is shut down:

The needle indicates the same value as the ambient temperature (within a few degrees) and the corresponding atmospheric pressure (between 150 and 350 PSI maximum).

If left unused for a long period of time :

Check the pressure gauge before starting up the heat pump. It must indicate at least 80 PSI.

If the pressure goes down too much, the heat pump will display an error message and automatically go into 'safe' mode.

This means that there has been a leakage of refrigerant and that you must call a qualified technician to replace it.

5.4 Antifreeze protection



WARNING: For the antifreeze system to work, the heat pump must be powered and the circulating pump activated. If the circulating pump is servo-controlled by the heat pump, it will be automatically activated.

When the heat pump is on standby, the system monitors the ambient temperature and the water temperature in order to activate the antifreeze programme if required.

The antifreeze programme is automatically activated when the ambient temperature or the temperature of the water is less than 2°C and when the heat pump has been shut down for more than 120 minutes.

When the antifreeze programme is running, the heat pump activates its compressor and the circulating pump so as to reheat the water until the water temperature exceeds 2°C.

The heat pump automatically leaves the antifreeze mode when the ambient temperature is greater than or equal to 2°C or when the heat pump is activated by the user.

6. Operation

6.1 Maintenance and servicing



WARNING: Before undertaking maintenance work on the unit, ensure that you have disconnected the electrical power supply.

Cleaning

The heat pump's casing must be cleaned with a damp cloth. The use of detergents or other household products could damage the surface of the casing and affect its properties.

The evaporator at the rear of the heat pump must be carefully cleaned with a vacuum cleaner and soft brush attachment.

Annual maintenance

The following operations must be undertaken by a qualified person at least once a year.

- ✓ Carry out safety checks.
- ✓ Check the integrity of the electrical wiring.
- ✓ Check the earthing connections.
- ✓ Monitor the state of the pressure gauge and the presence of refrigerant.

6.2 Winter storage

In the winter months when the ambient temperature is lower than 3°C, a shut-down heat pump must be winterised to avoid any frost damage.

Winterising in 4 steps



Step 1
Disconnect the heat pump from the power supply.

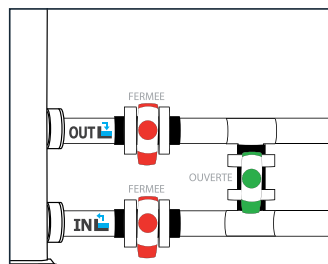

Step 2
Open the By-Pass valve. Close the inlet and outlet valves.

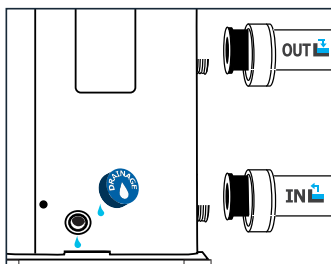

Step 3
Unscrew the drain plug and water pipes in order to drain any water from the heat pump.

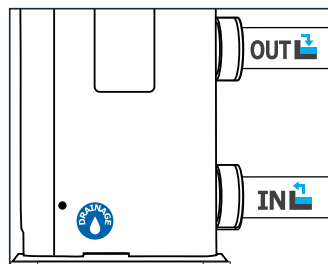

Step 4
Screw back the drain plug and pipes or block them with rags so as to prevent any foreign bodies from getting into the circuit. Finally, protect the pump with its winter storage cover.



If a circulating pump is servo-controlled by the heat pump, drain this also.

7. Repairs

7.2 List of faults

Code	Anomalies	Causes possibles	Actions
E0	Flow sensor malfunction	Not enough water in the exchanger	Check the good circulation of water in the heat pump, and the opening of the By Pass inlet/outlet valves
		Disconnected or faulty sensor	Reconnect or replace sensor
E01	Connection problem between the electronic card and the wired remote control	Bad connection	Check the connection cables between the remote control and the electronic board
		Faulty wired remote control	Replace the remote
		Defective electronic board	Replace the electronic card
E02	Connection problem between the electronic card and the inverter module	Bad connection	Check the connection cables between the inverter module and the electronic card
		Faulty inverter module	Replace the inverter module
		Defective electronic board	Replace the electronic card
E09	Air outlet temperature sensor malfunction	Disconnected or faulty sensor	Reconnect or replace sensor
E10	Ambient temperature sensor malfunction		
E14	Water outlet temperature too low	Flow rate too high in the heat pump, Sensor disconnected or faulty	Check that the water is circulating correctly in the heat pump, and that the By Pass inlet/outlet valves are open, Reconnect or replace the sensor
E15	Exchanger temperature too high (cooling mode)	Flow too low in the heat pump	Check the good circulation of water in the heat pump, and the opening of the By Pass inlet/outlet valves
E16	Water outlet temperature too high	Flow too low in the heat pump, Sensor disconnected or faulty	Check that the water is circulating correctly in the heat pump, and that the By Pass inlet/outlet valves are open, Reconnect or replace the sensor
E17	Insufficient water flow	Not enough water in the exchanger	Check the good circulation of water in the heat pump, and the opening of the By Pass inlet/outlet valves
E18 E19	High pressure protection, Low pressure protection	Insufficient water flow	Check the good circulation of water in the heat pump, and the opening of the By Pass inlet/outlet valves
		Refrigerant overload / leak	Readjust the refrigerant charge or call a refrigeration professional.
		Faulty 4-way valve	Replace the 4-way valve
		High pressure switch disconnected or faulty	Reconnect or replace pressure switch
E22	Too big difference between temp. water inlet and outlet	Not enough water in the exchanger	Check the good circulation of water in the heat pump, and the opening of the By Pass inlet/outlet valves
E23 E24	Ambient temperature too low	-	-
E25	Outlet water temperature too low for cooling mode	Insufficient water flow	Check the good circulation of water in the heat pump, and the opening of the By Pass inlet/outlet valves
E26	Fan wiring problem	Check the fan connection	Reconnect or change the fan

7. Repairs

E31	incorrect password	The password used is not valid	Verify and use the corresponding password
E38	Driver module protection, Control module protection		
E49	Water inlet temperature sensor malfunction	Disconnected or faulty sensor	Reconnect or replace sensor
E50	Evaporator sensor malfunction	Disconnected or faulty sensor	Reconnect or replace sensor
E51	Exhaust temperature too high	Lack of refrigerant	Readjust the refrigerant charge
E52	Suction sensor fault	Disconnected or faulty sensor	Reconnect or replace sensor
E53	Exchanger sensor fault	Disconnected or faulty sensor	Reconnect or replace sensor
E54	Room temperature sensor fault	Disconnected or faulty sensor	Reconnect or replace sensor
E57	Water outlet sensor fault	Disconnected or faulty sensor	Reconnect or replace sensor
I17	Inverter module protection	Restart the heat pump	If the problem persists, replace the inverter module
I22	Motherboard temperature too high	Obstructed Ventilation Areas, Defective Component	Check that the motherboard is not obstructed or dirty, Replace the motherboards
I32	Connection fault with the motherboard	Disconnected or faulty motherboard	Check motherboard wiring, Replace motherboard
I33	Inverter module link fault	Inverter module disconnected or faulty	Check inverter module wiring, Replace inverter module
I32	Connection fault with the motherboard	Disconnected or faulty motherboard	Check motherboard wiring, Replace motherboard
I33	Inverter module link fault	Inverter module disconnected or faulty	Check inverter module wiring, Replace inverter module

8. Recycling

8.1 Recycling the heat pump

Your heat pump has reached the end of its life and you wish to dispose of it or to replace it. Do not throw it in the rubbish bin.

A heat pump must be disposed of separately with a view to its reuse, recycling or upgrading. It contains substances that are potentially hazardous to the environment but which will be eliminated or neutralised by recycling.

YOU HAVE THREE SOLUTIONS:

①

Disposing of it at your local recycling centre

②

Giving it to a social service organisation for it to be repaired and put back into circulation.

③

Returning it to the heat pump distributor against a new purchase.

9. Warranty

9.1 General warranty conditions

The Irrijardin Company guarantees the original owner against defective materials and faults in the manufacture of the Irripool IR Alpha Inv Expert heat pump for a period of three (3) years.

The compressor is guaranteed for a period of five (5) years.

The titanium tube heat exchanger is guaranteed for a period of fifteen (15) years against chemical corrosion, except for frost damage.

The condenser's other components are guaranteed for three (3) years.

The warranty becomes effective on the date of the first invoice.

The warranty does not apply in the following cases:

- Malfunction or damage arising from an installation, usage or repair that is not in compliance with the safety instructions.
- Malfunction or damage arising from a chemical agent that is unsuitable for the pool.
- Malfunction or damage arising from conditions that are unsuitable for the equipment's purposes of use.
- Damage arising from negligence, accident or force majeure.
- Malfunction or damage arising from the use of unauthorised accessories.

Repairs undertaken during the warranty period must be approved prior to being carried out by an authorised technician. The warranty shall be null and void if the repair to the equipment is carried out by a person who is not authorised by the Irrijardin company.

The guaranteed parts shall be replaced or repaired at Irrijardin's discretion. Defective parts must be returned to our workshops to be covered during the warranty period. The warranty does not cover labour costs or unauthorised replacements. The return of the defective part is not covered by the warranty.

Dear,

**For any questions, or to contact the after-sales service,
Go to your Irrijardin store.**

**List of resellers available on:
www.irrijardin.fr**

Your details may be treated in accordance with the Data Protection Act of 6 January 1978 and will not be divulged to any third party.

10. Appendices

10.1 Schémas de câblage

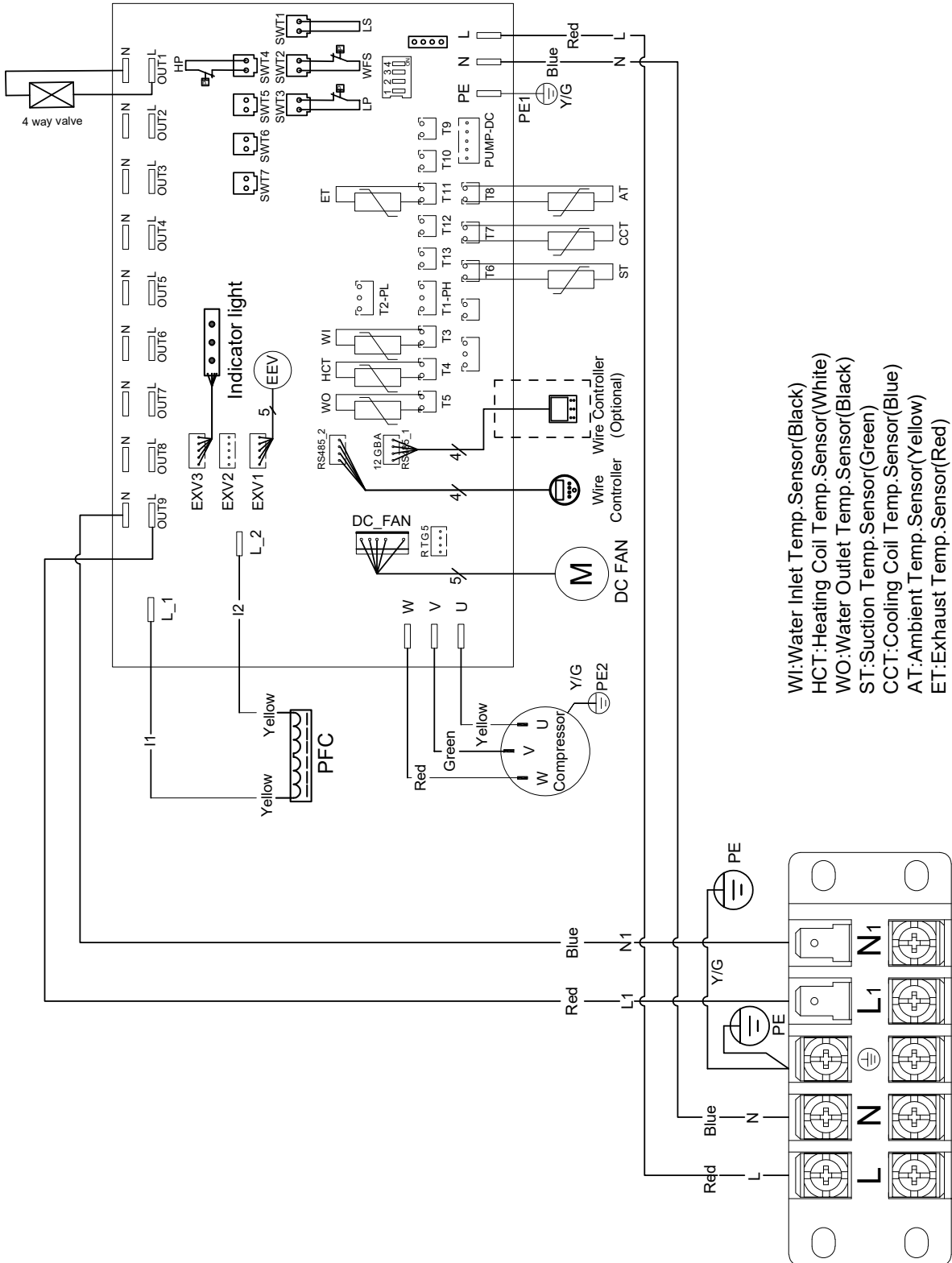

- WI:Water Inlet Temp. Sensor(Black)
- HCT:Heating Coil Temp.Sensor(White)
- WO:Water Outlet Temp.Sensor(Black)
- ST:Suction Temp.Sensor(Green)
- CCT:Cooling Coil Temp.Sensor(Blue)
- AT:Ambient Temp.Sensor(Yellow)
- ET:Exhaust Temp.Sensor(Red)
- WFS:Water flow switch
- LP:Low pressure protection
- HP:High pressure protection
- LS:Linkage switch(Short circuit)

Power Supply 220-240V~/50Hz
 Water pump 220-240V~/50Hz

Notice:When the power of water pump is more than 350W, must set the AC contactor outside.

10. Appendices

10.1 Wiring diagrams

IR ALPHA INV Expert 150

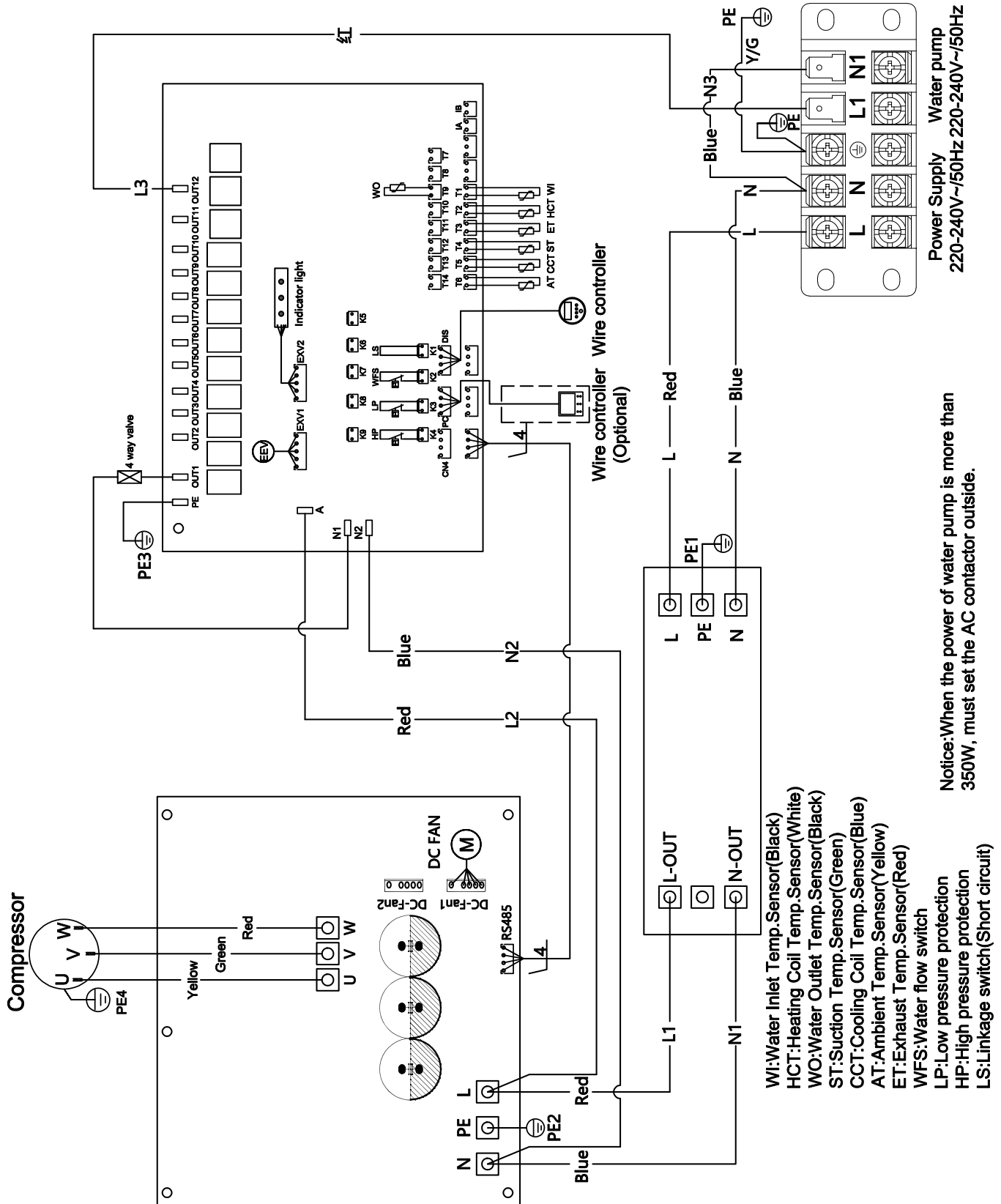

10. Appendices

Importé par Irrijardin
Route de toulouse
31410 Noé - France
www.irrijardin.fr